

## HEATER for CABINS

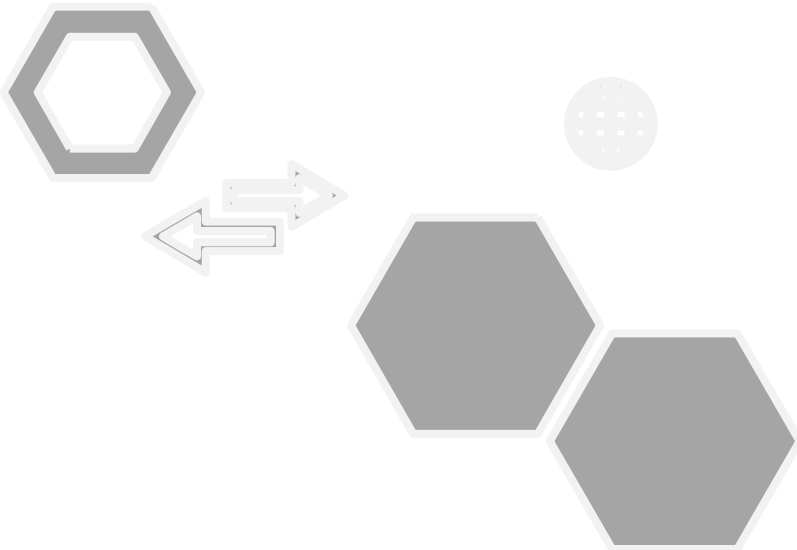

**Effective Control**  
For Industrial Applications  
**GLHE01**

# TECHNICAL PROPERTIES

## GENERAL

ADJUSTMENT	/ FOR CABIN INTERIOR
INSTALLATION	/ FLOOR MOUNT
MATERIAL	/ ST37 BODY
TEMPERATURE	/ -10 C TO +55 C (STANDARD)
APPLICATION	/ OPERATOR CONTROL CABIN
VOLTAGE	/ 230VAC 50 Hz
SPEED	/ 2650 RPM
AIR FLOW	/ 160 M <sup>3</sup> /H
SOUND	/ 46 dB(A)
POWER FOR FAN	/ 19 W
POWER FOR RESISTANCE	/ 1000 W
AIR INLET-OUTLET TEMP. DIFFERENCE	/ 25 °C

## COATING

BODY	/ ELECTROSTATIC GALVANIZED COA. / COLOR OPTIONAL / 80 µM
------	--



It can be used in interior floor parts of the cabin

Air is directed towards the lower windshield.

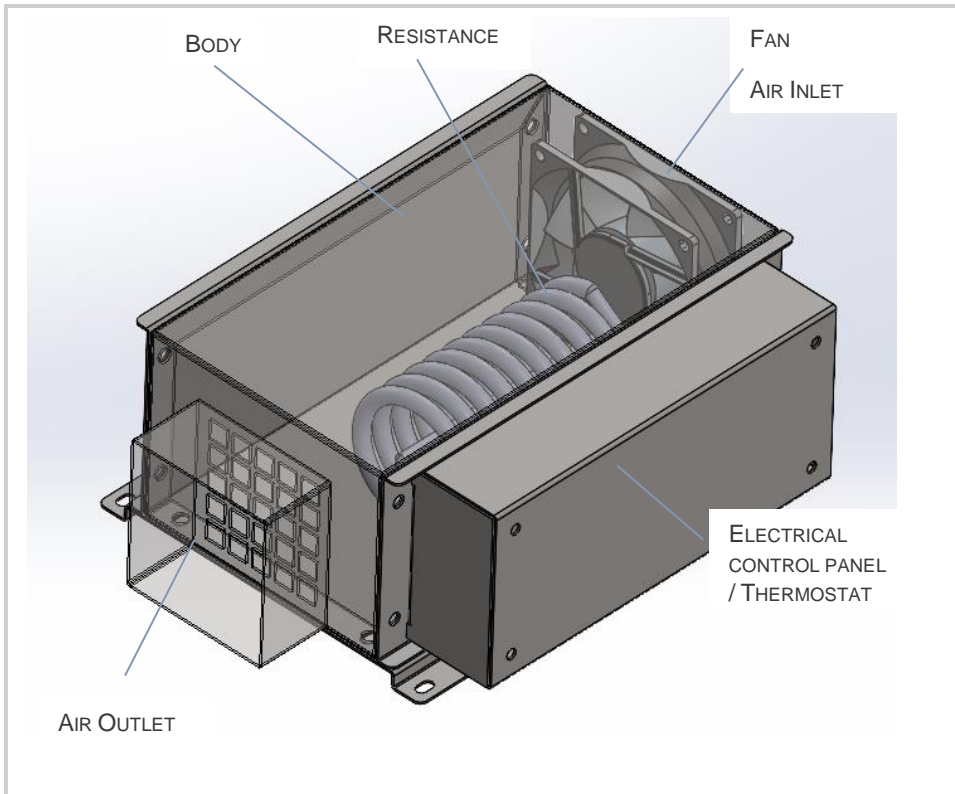

## DIMENSIONS

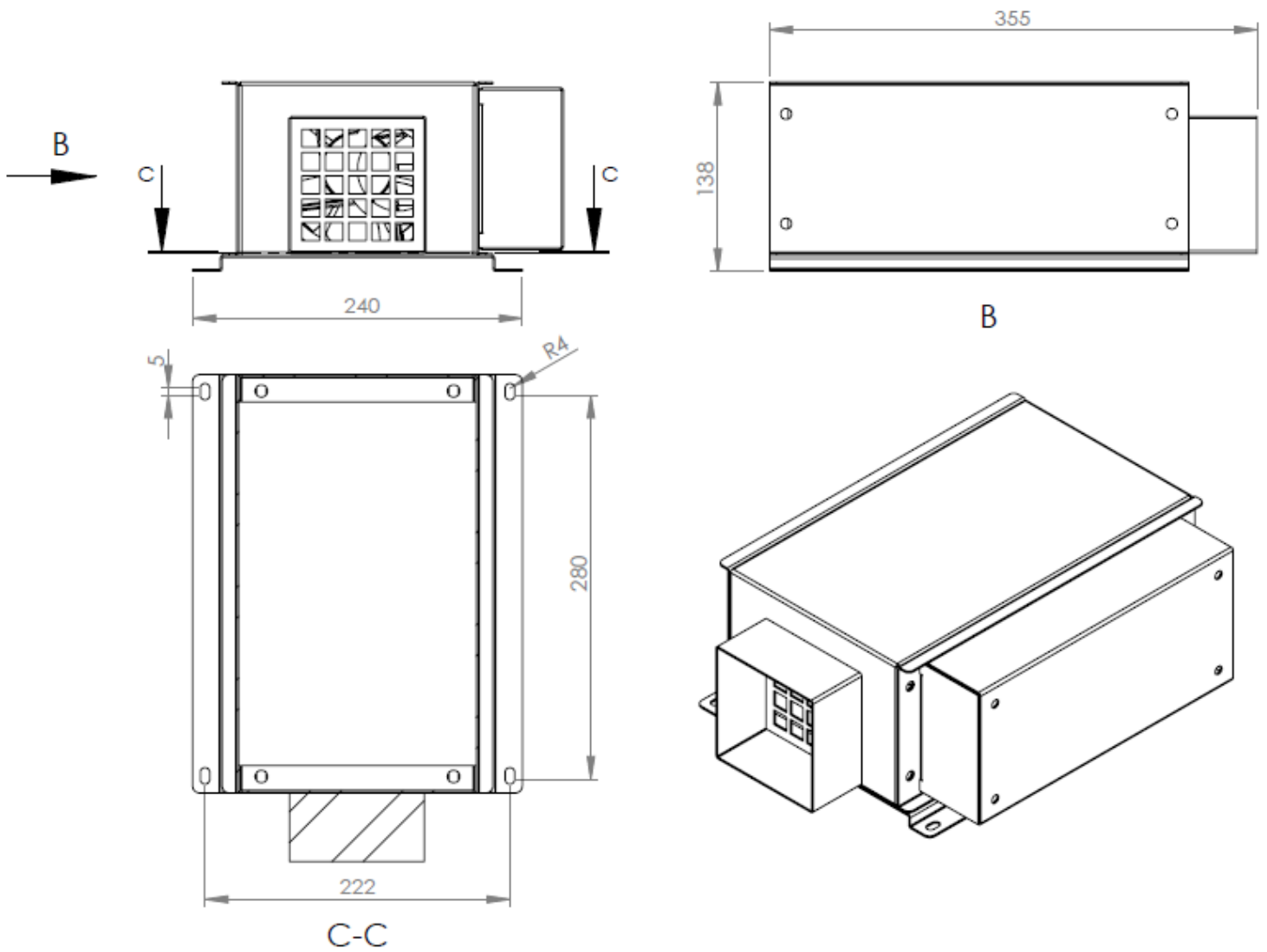

All dimensions are in mm.



## **GL Makina Ltd. Co.**

Phone : +90 312 395 63 17

Fax : +90 312 395 64 17

[www.glmakina.com](http://www.glmakina.com)

[info@glmakina.com](mailto:info@glmakina.com)